

810 series Mounting Brackets, Tubing & Connectors

Specification Sheet 1 (last updated May 2019)



The ever popular WPL 810 series peristaltic pumps are available in a range of AC and DC motor options and various tube size combinations delivering flow rates as high as 987 ml/min. They are self priming up to 29 ft. (8.8m), can be run dry continuously, and are non-siphoning.

The easiest way to place an order or check prices is via our online shop at <http://www.williamson-shop.co.uk> but please contact us for any requirements not listed or to place an order over the phone.

810 series Mounting Brackets

- L L shaped
- F Flat
- K Kit (no bracket)

Add above code as suffix to pump model number to select chosen bracket. eg. 810-143-230-250/2-L would have an L shaped bracket. Where no suffix is shown the flat plate will be supplied.

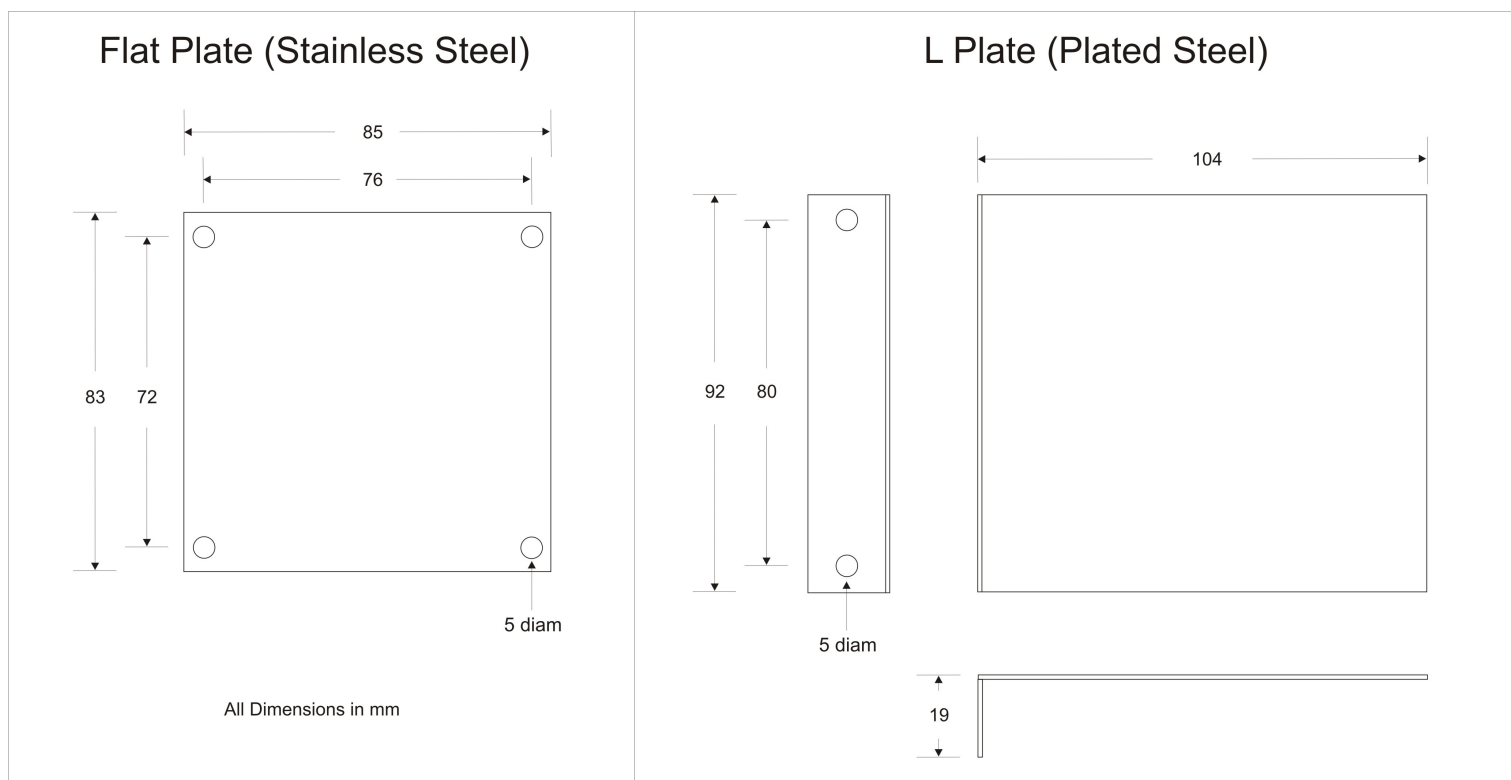

Williamson Manufacturing Company Ltd

Unit 5, Lady Bee Industrial Estate, Albion Street, Southwick, West Sussex, BN42 4EP, UK.
Tel +44(0)1273 857752 E Mail:- sales@williamsonpumps.co.uk Web www.wmcpumps.com

810 series Mounting Brackets, Tubing & Connectors

Specification Sheet 2

810 series Tubing

55 Food Grade Santoprene

SANT55-4.8x2.4-230	Santoprene tubing - food grade 4.8mm ID x 2.4mm wall 55 shore, cut length of 230mm with tube stop
SANT55-4.8x2.4/1M	Santoprene tubing - food grade 4.8mm ID x 2.4mm wall 55 shore, per metre
SANT55-6.4x2.4-230	Santoprene tubing - food grade 6.4mm ID x 2.4mm wall 55 shore, cut length of 230mm with tube stop
SANT55-6.4x2.4/1M	Santoprene tubing - food grade 6.4mm ID x 2.4mm wall 55 shore, per metre

Silicone - Peroxide cured

SIL-4.8x2.4-230	Silicone tubing -peroxide cured 4.8mm ID x 2.4mm wall, cut length of 230mm with tube stop
SIL-4.8x2.4/1M	Silicone tubing - peroxide cured 4.8mm ID x 2.4mm wall, per metre
SIL-6.4x2.4-230	Silicone tubing - peroxide cured 6.4mm ID x 2.4mm wall, cut length of 230mm with tube stop
SIL-6.4x2.4/1M	Silicone tubing - peroxide cured 6.4mm ID x 2.4mm wall, per metre

810 series Connectors

Polypropylene

Micro 5	Barbed connector - to suit 4.8mm ID tubes
GS6-PP	Barbed connector - to suit 6.4mm ID tubes
GRS6-4-PP	Reducing barbed connector to step down from 6.4mm ID to 4mm ID tubes

Acetal

GS6	Barbed connector - to suit 6.4mm ID tubes
GRS6-4	Reducing barbed connector to step down from 6.4mm ID to 4mm ID tubes
GRS6-8	Reducing barbed connector to step up from 6.4mm ID to 8mm ID tubes
GRS6-10	Reducing barbed connector to step up from 6.4mm ID to 10mm ID tubes

Williamson Manufacturing Company Ltd

Unit 5, Lady Bee Industrial Estate, Albion Street, Southwick, West Sussex, BN42 4EP, UK.
Tel +44(0)1273 857752 E Mail:- sales@williamsonpumps.co.uk Web www.wmcpumps.com